

# Performance Analysis System

## for Swimming Starts, Turns and Relay Changeovers

Type 9691A1

Kistler Performance Analysis System for Swimming is a comprehensive system to analyze, compare and improve swimming starts, turns and relay changeovers. This portable system can be installed in most standard swimming pools and includes force measurement, high-speed video capturing and software to analyze and compare different trails.

- Portable system for most swimming pools
- Underwater cameras
- Instant feedback for coaches and athletes
- Comparison of trials and athletes
- Export and replay trials on other devices
- Chlorine water resistant

### Description

Kistler Performance Analysis System for swimming provides kinetic and kinematic information about starts, turns and relay changeovers immediately.

Two multi-component force plates on top of the solid start block are recording the forces for each leg separately. An instrumented grab bar measures the force exerted by the hands and arms for different types of starts. The portable turning plate is easy to install and does not require any construction work on the pool wall. Its large size and the very slim design allow measurements of starts and turns without affecting the elite swimmers movement.

Five high-speed video cameras are capturing the swimmers moves over and under water at 100 fps. They allow precise measurement of position and split times over 15 m distance at high resolution. The data acquisition system provides a frame-by-frame synchronization of force plate and video data. The software displays the video along with a biomechanical analysis of the kinetic and kinematic information in a way easy to understand.

### Application

The major characteristics of Kistler's Performance Analysis System for Swimming are its ability to provide almost immediate feedback and a comparison of two different trials on one screen. This can be either one athlete at different times or two different athletes.



In competitive swimming, the performance in start and turns is a key element to achieve better results. A better starter can be over 0.5 s faster than a poorer starter over the first 15 m, while only a few hundredth of a second can decide a sprint race. In long distance races a minor time win per turn can sum up to several seconds over the whole race.

Kistler Performance Analysis System for Swimming assists coaches in the analysis and correction of technique regarding start and turn. The biomechanical analysis that the system is providing enhances the elite swimmer's skills in these fields effectively. This is especially beneficial since the enhancement of these skills will improve the performance of the athlete without consuming any more energy in the free swimming.

Instantly after the swimmer has passed the 15 m mark, detailed information on the force data and the high-speed video are available. The presentation of the complete biomechanical analysis of the trial takes only about one minute. All data is synchronized with the start signal to determine the split times for the first 15 m. The Performance Analysis System for Swimming presents the most relevant data superimposed over the visual image of the video. The same screen shows detailed information and charts.

## Technical Data

### Solid Starting Block

Multi-component force plates to measure both feet separately (front/rear)		2
Multi-component grab force measurement for starts from block and for backstroke start		1
Front height	mm	400
Dimensions	mm	782x520
Weight	kg	79
Integrated charge amplifiers for all components		
Degree of protection (EN60529:1992)		IP65
Chlorine water resistant		

### Backstroke Start and Turning Force Plate

Multi-component force plate to measure forces of backstroke starts and turns		1
Dimensions	mm	900x600
Thickness	mm	40
Weight	kg	28
Integrated charge amplifier		
Degree of protection (EN60529:1992)		IP68
Chlorine water resistant		

### Waterproof High Speed Cameras

Cameras to provide complete visual image from start to 15 m distance		5
High resolution color image		
Frame rate	fps	100
Degree of protection (EN60529:1992)		IP68
Camera mounts for pool wall		

### Data Acquisition System

16 bit resolution for analog data		
Frame-by-frame synchronization for visual image and analog data		
Degree of protection (EN60529:1992)		IP52

### PC and Software

16 GB RAM		
Database to store and compare trials		
Data capture, data analysis, data replay, data export		
Export trials to external device or viewer		

### Biomechanical Analysis Includes:

- Reaction time
- Time on block
- Power from start/turn
- Forces from start/turn
- Take off angle and velocity
- Diving angle and velocity
- Diving distance from start
- Diving depth
- Displacement at brake out point
- Split times 5 m, 10 m, 15 m
- And many more...
- Synchronized with start signal or touch of incoming swimmer for relay changeovers

### System Overview

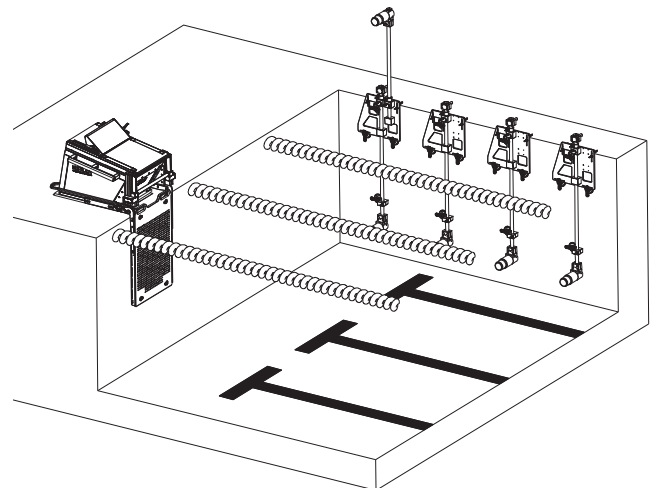

Fig. 1: Force measurement and cameras in swimming pool

**Dimensions**

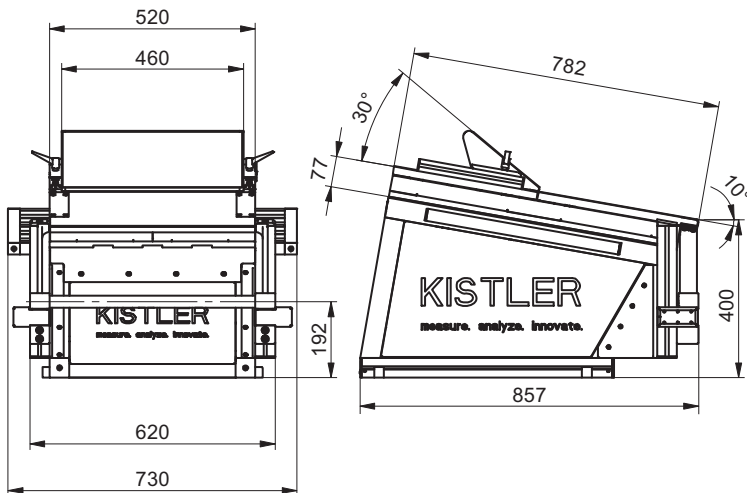

Fig. 2: Dimensions of starting block

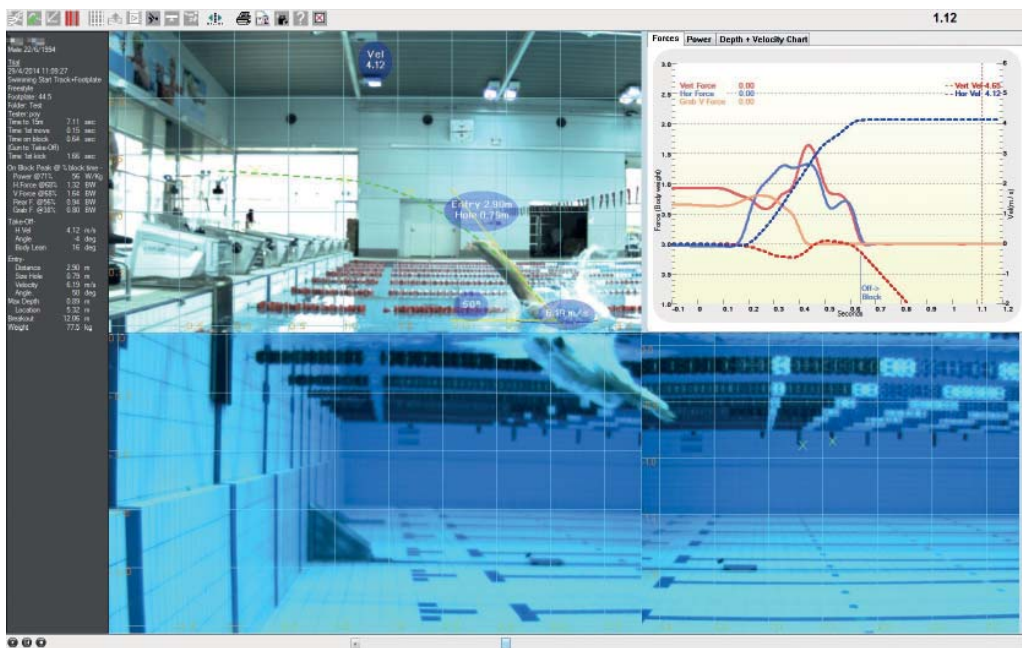

Fig. 3: Screen-shot

**Included Accessories**

- Start system
- Laser distance-meter
- Calibration tool

**Type/Mat. No.**

- 55140795
- 55144815
- 55143621

**Ordering Code**

- Performance Analysis System for Swimming Starts, Turns and Relay Changeovers

**Type 9691A1**

9691A\_003-134e-11.15